

## 2<sup>nd</sup> G Standard Multihead Weigher

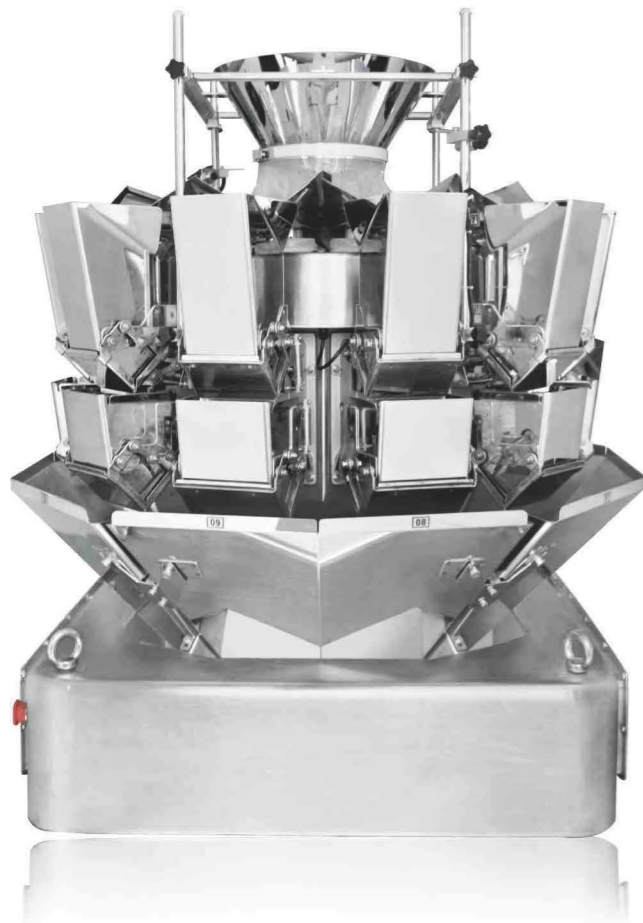
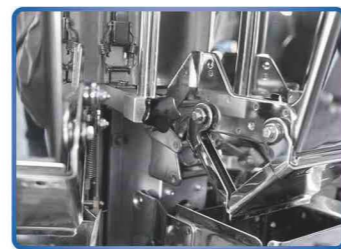
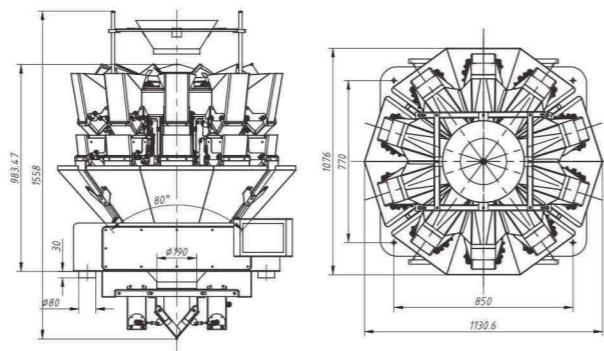
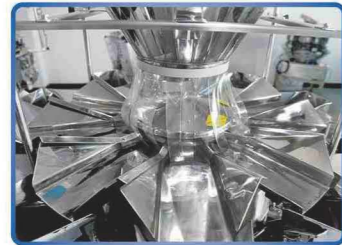

### Application

It is suitable for weighing candy, seeds, jelly, pet foods, puffy foods, pistachio, peanuts, nuts, raisins, dried fruits, frozen foods, snack foods, hardware, meatballs, etc.

### Features

1. High accuracy and tailored load cell.
2. Intelligent multi-sampling stable mode, higher accuracy.
3. Intelligent alarm diagnosis.
4. High speed stagger dump function.
5. Modular and CAN bus technology, more efficient and stable.
6. Modbus Industry communication protocol.

### Mechanical Character

1. 1.6L/2.5L hopper, a wide range application to different of products.
2. 7" touch screen can meet the user's requirement.
3. New actuator design reduce the mechanical vibration and improves the load cell value accuracy.
4. Arc-shaped machine body with large R treatment improves the stability and appearance.
5. Uniform design standards, and mould processing, contribute to better interchangeability for spare parts.
6. Integral machine frame and machine cabinet contributes to more stability and higher accuracy.

### Technical Specification

Model	FT-A10	FT-A14
Identify Code	A10-2-1D	A14-2-1D
Weighing Range	10~1000g	10~1500g
Accuracy	X(0.5)	X(0.5)
Max Speed	65P/M	120P/M
Hopper Volume	1.6L/2.5L	
Control Panel	7" Touch Screen	
Options	Dimple Plate /Timing Hopper /Printer / Reject Device	
Driving System	Step Motor	
Power Requirement	220V / 1000W / 50/60Hz / 10A	220V / 1000W / 50/60Hz / 10A
Packing Dimension(mm)	1620(L)x1080(W)x1120(H)	1700(L)x1080(W)x1210(H)
Gross Weight	400kg	500kg