

Weigher for Stick-shaped Products

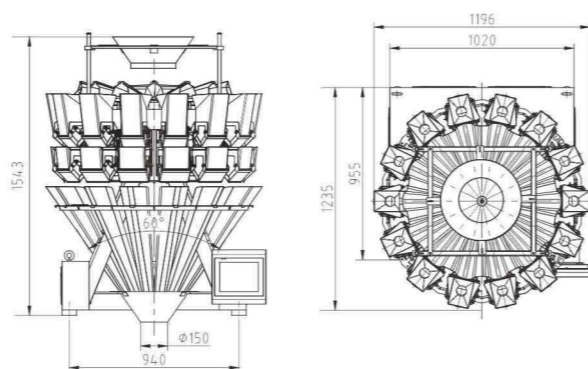

Application

It is suitable for weighing stick shaped products, such as sausage, salty sticks, chopsticks, pencil, etc. max 200mm length.

Features

1. High-precision, high-standard special load cell, resolution up to 2 decimal places.
2. Program recovery function can reduce operation failures, Support multi-segment weight calibration.
3. No products auto pause function can improve weighing stability and accuracy.
4. 100 programs capacity can meet various weighing requirement, user-friendly help maun in touch screen contributes to easy operation.
5. Linear amplitude can be adjusted independently, can make the feeding more uniform.

6. 15 languages available for global markets.

Mechanical Character

1. Special rotary top cone dispense products evenly to each linear feeder pan.
2. Special linear feeder pan to make sure of feeding process.
3. Special hopper design to keep the material in a vertical state.
4. Independent discharge chute can make sure that material discharge into packaging machine vertically.
5. Optional weighing type material detection, accurate control of feeding time, material thickness, to ensure the accuracy of the weighing.
6. The whole cast aluminum thickening machine case enhanced the strength of the machine, and shorten sample stable time.

Technical Specification

Model	FT-A10	FT-A14	FT-AS14	FT-AM14
Identify Code	A10-1-9	A14-1-9	AS14-1-9	AM14-1-9
Weighing Range	10~1000g	10~1500g	3~200g	10~3000g
Accuracy	X(0.5)	X(0.5)	X(0.5)	X(1)
Max Speed	30P/M	60P/M	60P/M	60P/M
Hopper Volume	2.5L	2.5L	0.5L	5L
Control Panel	7" Touch Screen			
Options	Dimple Plate / Timing Hopper / Printer / Reject Device			
Driving System	Step Motor			
Power Requirement	220V / 2000W / 50/60Hz / 12A	220V / 2000W / 50/60Hz / 12A	220V / 1100W / 50/60Hz / 10A	220V / 2000W / 50/60Hz / 12A
Packing Dimension(mm)	1620(L)x1100(W)x1420(H)	1750(L)x1130(W)x1420(H)	1190(L)x970(W)x950(H)	2195(L)x1380(W)x2060(H)
Gross Weight	490kg	490kg	240kg	650kg