

Super Mini Weigher (Super high precision)

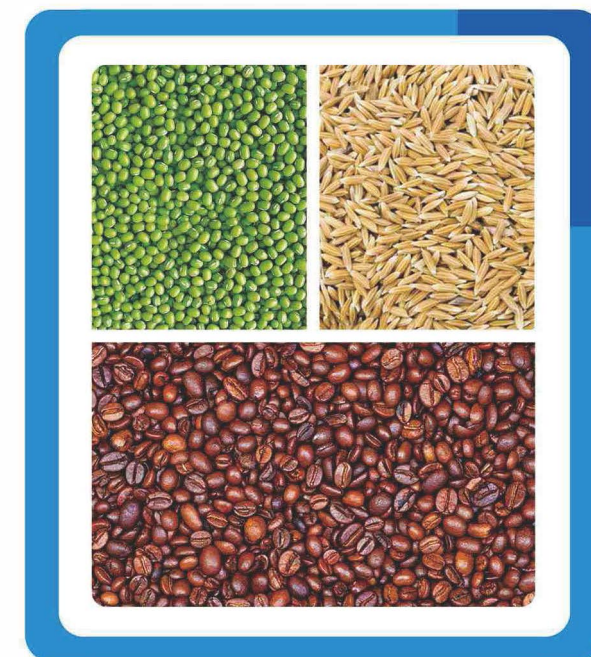
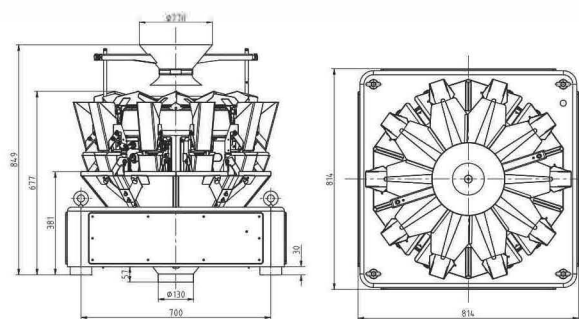

Application

It is suitable for weighing small weight granules such as seeds, tea, coffee beans etc.

Features

1. Adopt high accurate loadcell of famous brand, resolution is improved up to 2 decimal.
2. Program recovery function can reduce operation failures and support multi-segment weight calibration.
3. No products auto pause function can improve weighing stability and accuracy.
4. 100 programs capacity can meet various weighing requirements and user-friendly help menu contributes to easy operation.
5. Linear amplitude can be adjusted independently.
6. Many languages available for global markets.

Mechanical Character

1. 0.3L hopper, low vibrating design, good performance.
2. New double parallel linear vibrator contributes to smaller vibration, side-driven actuator makes the reading more accurate and the weighing accuracy higher.
3. Use weighing type for material detection to make accurate control of feeding time & material thickness and ensure weighing accuracy.
4. V feeder pan especially designed for small target weight to ensure even feeding and weighing accuracy.
5. Integral machine frame with middle standing enhances the strength of the machine, making the time for stabilizing hoppers much shorter.
6. Arc-shaped machine body with large R treatment improves the stability and appearance.

Technical Specification

Model	FT-A10	FT-A14
Identify Code	AS10-1-2	AS14-1-2
Weighing Range	5~60g	5~60g
Accuracy	X(0.5)	X(0.5)
Max Speed	60P/M	120P/M
Hopper Volume	0.3L	
Control Panel	7" Touch Screen	
Options	Dimple Plate /Timing Hopper /Printer / Reject Device	
Driving System	Step Motor	
Power Requirement	220V / 900W / 50/60Hz / 8A	220V / 1100W / 50/60Hz / 10A
Packing Dimension(mm)	1190(L)x970(W)x950(H)	1190(L)x970(W)x950(H)
Gross Weight	180kg	220kg