

Dropped metal detector

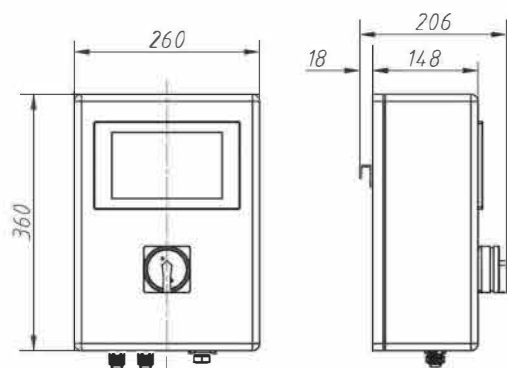

Controller



Detector

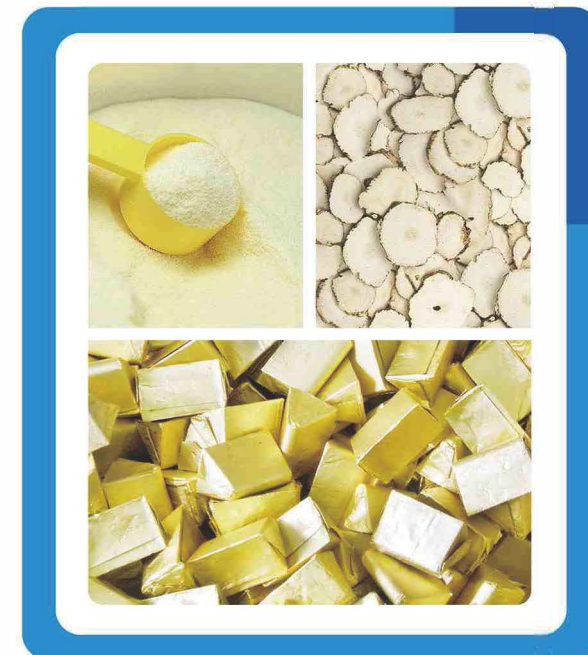
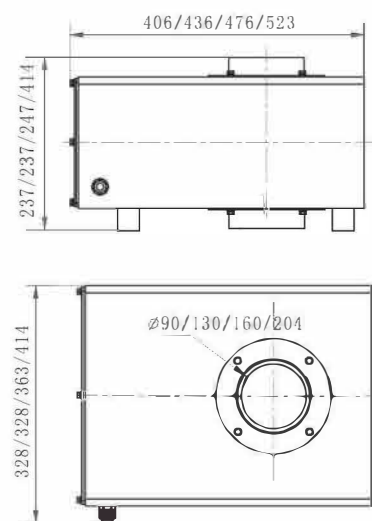

Application

Applied for checking powders, granules and sheet materials.

Mechanical Character

1. Checking size 120mm, thin body design, save space.
2. Separated detector head and controller design, easy operate.

Features

Suitable for being fixed between the bottom of weigher and the top of VFFS feeding funnel, or other dropping condition..

Technical Specification

Model	FT-GX80	FT-GX120	FT-GX150	FT-GX200	
Identify Code	GX80-1-1	GX120-1-1	GX150-1-1	GX200-1-1	
Sensitivity	Fe	0.8mm	1.0mm	1.2mm	1.5mm
	SUS	1.5mm	2.0mm	2.5mm	3.0mm
Checking Speed	Free Falling Speed				
Checking Size(diameter)	Φ80mm	Φ120mm	Φ150mm	Φ200mm	
Control Panel	7" Touch Screen				
Power Requirement	220V / 50Hz				
Machanical Size	395(L)x305(W)x260(H)	430(L)x305(W)x260(H)	465(L)x305(W)x260(H)	515(L)x305(W)x260(H)	
Machanical Weight	44kg	46kg	54kg	65kg	